

# **TC-650PD2**

## **Switching Power Supply**

(EPS12V)

# **SPECIFICATION**

Revision: 1.0

727. Phillips Drive City of Industry. CA 91748. USA  
[http:// www.istarusa.com](http://www.istarusa.com)  
TEL: 626-3038885    FAX: 626-3010588

**\*\* Table of Content \*\***

<b>1. Input Requirements.....</b>	<b>04</b>
1-1. Input Voltage.....	04
1-2. Frequency.....	04
1-3. Inrush Current.....	04
1-4. AC Input Current.....	04
1-5. Efficiency.....	05
<b>2. Output Requirements.....</b>	<b>05</b>
2-1. Output Regulations.....	05
2-2. DC Load Requirements.....	05
2-3. Cross Regulation .....	06
2-4. +5V Standby Voltage.....	06
2-5. DC Output Voltage Ripple And Noise.....	06
2-6. Total Output Power.....	06
2-7. Remote ON/OFF Control.....	07
2-8. Power Sequence.....	07
2-9. Power on Time (T1).....	07
2-10. Rise Time (T2).....	07
2-11. Power Good Delay Time (T3).....	07
2-12. Power Good Rise Time (T4).....	08
2-13. Hold Up Time (T5).....	08
2-14. Power Fail Signal (T6).....	08
<b>3. Protections.....</b>	<b>08</b>
3-1. Over Voltage Protection.....	08
3-2. Short Circuit Protection.....	08
3-3. Protection Reset.....	09
3-4. Over Shoot.....	09
3-5. Over Power Protection.....	09
<b>4. Environment.....</b>	<b>09</b>
4-1. Operation/Storage Temperature Range.....	09
4-2. Humidity.....	09
4-3. Altitude.....	09
<b>5. Safety.....</b>	<b>09</b>
<b>6. EMI Requirements.....</b>	<b>10</b>
<b>7. Dielectric Voltage Withstand (HI-POT).....</b>	<b>10</b>

8.	PFC.....	10
9.	Electrostatic Discharge Requirement (ESD).....	10
10.	EFT/Burst.....	10
11.	Surge.....	10
12.	Burn-In.....	10
13.	MTBF.....	10
14.	Dimension.....	10

**1. Input Requirements**

**1-1. Input Voltage**

The power supply shall be operated at universal input voltage defined in the following table.

Input Voltage	MIN	NOM	MAX
Voltage	90	100-240	264

**1-2. Frequency**

The input frequency range is from 50Hz to 60Hz.

**1-3. Inrush Current**

The max inrush current is 80A for 115/230VAC.

**1-3-1. Cold Start**

Conditions	Limits
115/230VAC, full load. 25°C ambient.	No component over stress or damage should occur to the power supply. Input fuse shall not blow.

**1-3-2. Warm Start**

Conditions	Limits
Turn off at 132/264VAC full load for 1 sec then turn on at the peak of the input voltage cycle at 25°C ambient.	No component over stress or damage should occur to the power supply. Input fuse shall not blow.

**1-4. AC Input Current**

AC Input	MAX	Units
100~240V	9	AMPS

### 1-5. Efficiency

Maximum 76% at 115V and 80% at 230V, under loading of spec 2-2.

## 2. Output Requirements

### 2-1. Output Regulations

Output Voltage	Range	MIN	Nominal	MAX	Units
+5V	±5%	+4.80	+5.00	+5.25	Volts
+12V1	±5%	+11.52	+12.00	+12.60	Volts
+12V2	±5%	+11.52	+12.00	+12.60	Volts
+12V3	±5%	+11.52	+12.00	+12.60	Volts
+12V4	±5%	+11.52	+12.00	+12.60	Volts
-12V	±10%	-11.40	-12.00	-13.08	Volts
+3.3V	±5%	+3.20	+3.30	+3.46	Volts
+5Vsb	±5%	+4.85	+5.00	+5.25	Volts

Note: 1). The above voltage range should also include ripple and noise.

2). The output voltage should be measured at the terminals of output connector.

### 2-2. DC Load Requirements

Output Voltage	MIN	NOM	MAX	Units
+5V	0.5	15	30	AMPS
+12V1	0.5	8	16	AMPS
+12V2	0.5	8	16	AMPS
+12V3	0.5	8	16	AMPS
+12V4	0.5	8	16	AMPS
-12V	0.0	0.4	0.8	AMPS
+3.3V	0.5	12.5	25	AMPS
+5Vsb	0.0	1.5	3	AMPS

Note : 1). The maximum continuous total DC output power shall not exceed 650 Watts.

2). The maximum continuous combined load on +5V and +3.3V outputs shall not exceed 170 Watts.

3). The maximum continuous combined load on +5V, +3.3V and +12V1,+12V2,+12V3,+12V4 outputs shall not exceed 635 Watts.

**2-3. Cross Regulation**

The DC loads shall remain within the ranges specified in 2-2 DC Load Requirements and the DC output voltages also shall remain within the regulation ranges specified in 2-1 Output Regulation when measured at the load end of the output connectors.

	+5V	+3.3V	+12V1	+12V2	+12V3	+12V4	-12V	+5VSB
1	0.5	25	12	12	12	12	0.8	3
2	30	0.5	11	11	11	11	0.8	3
3	10	12	0.5	16	16	16	0.8	3
4	10	12	16	0.5	16	16	0.8	3
5	10	12	16	16	0.5	16	0.8	3
6	10	12	16	16	16	0.5	0.8	3

**2-4. +5V standby voltage**

The +5Vsb is on whenever the AC power is present.--

**2-5. DC Output Voltage Ripple and Noise**

Output Voltage	Ripple & Noise Max	Units
+5V	50	mV
+12V1	120	mV
+12V2	120	mV
+12V3	120	mV
+12V4	120	mV
-12V	120	mV
+3.3V	50	mV
+5Vsb	50	mV

Note : 1)The measurements should be made by crossing a 10uF/ electrolytic and a 0.1uF ceramic disk capacitors at each output with measuring bandwidth from DC to 20 MHz. If ambient temperature is under 20°C or over 30°C, the AC input should be nominal input.

**2-6. Total Output Power**

MAX	Units
650	Watts

**2-7. Remote ON/OFF Control**

The power supply outputs shall be enabled with an active-low TTL signal.

When TTL signal is low, the DC outputs are to be enabled.

When TTL signal is high or open circuited, the DC outputs are to be disabled.

Electronic means or a mechanical switch may activate the TTL signal.

After the TTL signal is active high, must wait for 3 seconds before active low again.

**2-8. Power Sequence**

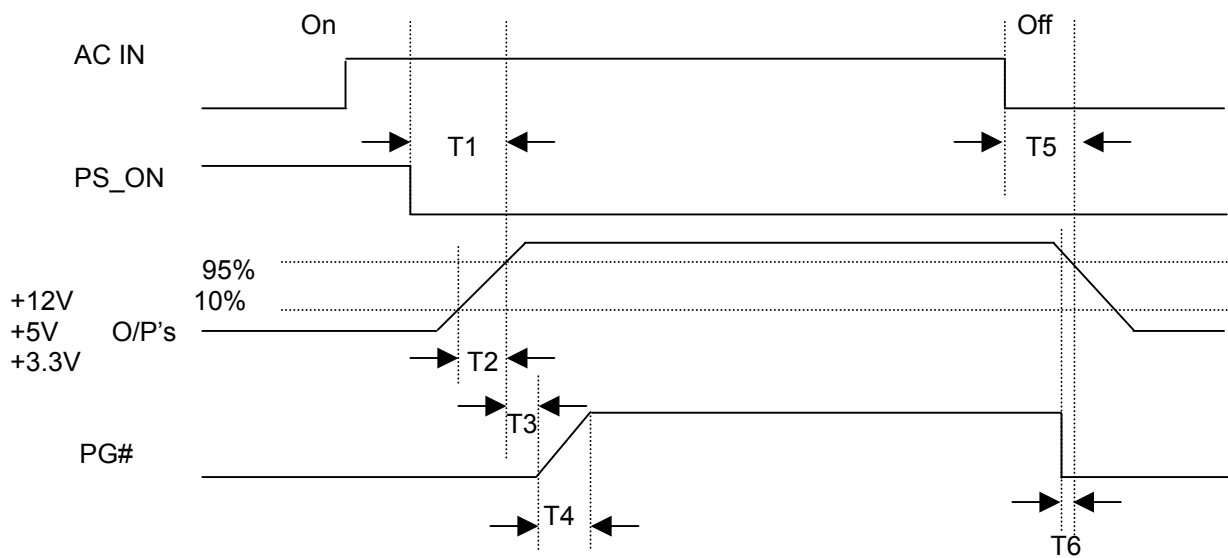

**2-9. Power On Time (T1)**

MAX	Units
500	ms

**2-10. Rise Time (T2)**

MIN.	MAX.	Units
5	50	ms

**2-11. Power Good Delay Time (T3)**

MIN.	MAX.	Units
100	500	ms

The test environment is 25°C condition @ nominal input.

**2-12. Power Good Rise Time (T4)**

MAX	Units
10	ms

**2-13. Hold Up Time (T5)**

MIN.	Units
18	ms

The test environment is 25°C & full load condition @ nominal input.

**2-14. Power Fail Signal (T6)**

Power good signal shall go to a down level 1ms before +5V output voltage falls below the regulation limits during PS-ON signal pull high.

MIN.	Units
1	ms

**3. Protections****3-1. Over Voltage Protection**

When the DC outputs (+5V, +12V1,+12V2,+12V3,+12V4 +3.3V,-12V,+5VSB) have over voltage condition, the power supply shall provide latch mode over voltage protection.

DC output	Max	Unit
+12V1,+12V2,+12V3,+12V4	14.5	V
+5V	6.5	V
+3.3V	4.5	V
-12V	-14.5	V
+5VSB	6.5	V

**3-2. Short Circuit Protection**

A short circuit placed to ground shall cause no damage or power supply shall be shutdown. (The contact resistance is 0.05 ohm when the outputs short circuit.)



**3-3. Protection Reset**

When the power supply latches into shutdown condition due to a fault on an+5V,+3.3V,+12V1,+12V2 +12V3,+12V4 output(OCP, OVP, UVP), the protection shall reset after the fault has been removed, use remote on/off control or recycle the AC power again for a typical of 3 seconds.

Note : +3.3V OCP maximum 150%.+5V OCP maximum 150%.+12V1&12V2&+12V3&+12V4 OCP maximum 20A.

**3-4. Over Shoot**

Any output overshoot at turn on shall be less than 15% of the nominal output value (with resistive load) as described in sec. 2.1.

**3-5. Over Power Protection**

At 115/230Vac input the power supply will shut down all DC output within 110% to 150% of full load.

**4. Environment**

**4-1. Operation/Storage Temperature Range**

Operation : 0°C to 50°C (nominal input)

Storage : -40°C to 70°C

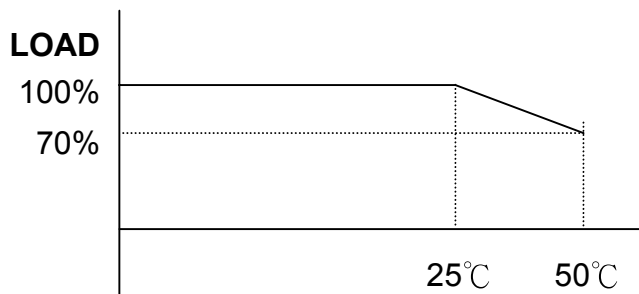

**4-2. Humidity (none condensing)**

Operation: 20% to 85% RH(nominal input)

Storage : 10% to 95% RH

**5. Safety**

5-1. UL60950-1,

5-2. TUV EN 60950

5-3. CB

**6. EMI REQUIREMENTS**

6-1.CE

6-2.BSMI

6-3.FCC part 15 sub part J class B at system load

6-4.CISPR 22 CLASS B

**7. Dielectric Voltage Withstand (HI-POT)**

The power supply shall withstand for 3 seconds without breakdown the application of an 1800Vac-supply voltage applied between both input line and chassis (10mA AC Cutoff current). Isolating transformers shall similarly withstand 4242Vdc applied between both primary and secondary windings for a minimum of one minute.

**8. PFC**

Active Power Factor Correction, complies with EN 61000-3-2: 1995+A1+A2:1998, Class D.

**9. Electrostatic Discharge (ESD)**

Comply with IEC 61000-4-2.

**10. EFT/ Burst**

Comply with IEC 61000-4-4.

**11. Surge**

Comply with IEC 61000-4-5.

**12. Burn-In**

Applying 115 Vac  $\pm$  10 % or 230 Vac  $\pm$  10% input voltage and maximum load (80%) for this product in 45  $\pm$  5 °C chamber.

**13. M.T.B.F.**

The power supply shall have a minimum mean time between failure greater than 100,000 hours at continuous operation of 100% load and an ambient temperature of 25°C .

**14. Dimension.**

180(D)X 150(W)X 86(H) mm.